

K746



500 nits



IP66



Fanless



WiFi



RFID

Features

- 12.1" True-Flat PCAP Touch
- Intel Bay Trail Processor
- Front IP66, Rear IP20
- Fanless and Silent
- Isolated DI/DO, RS232 & RS232/422/485 by Terminal Block with Strain Relief
- RFID/ WiFi + BT Available
- Front Key-Secured Lock for USB & Power Switch
- Best Panel Mount IPC Solution for Automation Application



As labor costs are increasingly growing, companies in the automation industry are looking to make their factories smarter through improving efficiency, lowering human labor, and continuing to guarantee high product quality. Flytech provides a wide range of industrial touch Panel PC products in different form factors, high brightness displays, and customizable high performance hardware configurations that are designed and certified to work under harsh environments and various automation applications.

K746

Industrial Automation Touch Panel Mount PC

FLYTECH
www.flytech.com

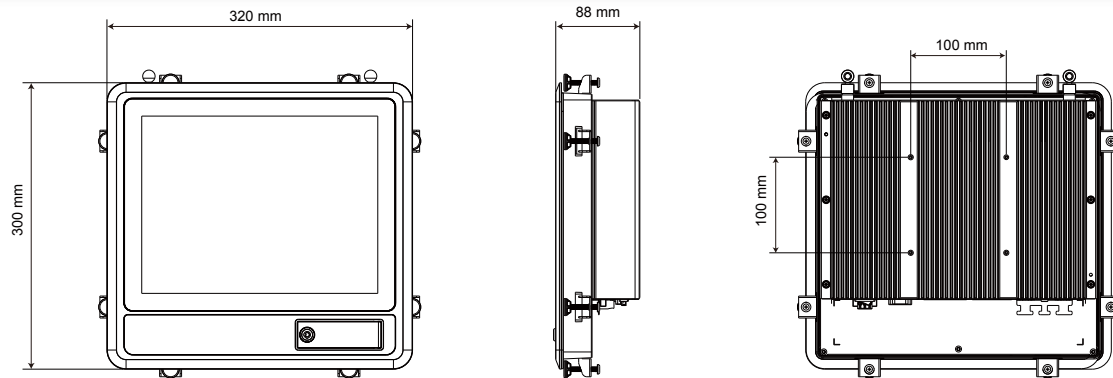

Specification

System	Motherboard Processor Chipset System Memory Storage Device Graphic Engine	D35 Intel Bay Trail CPU Celeron J1900 2.4GHz CPU Integrated 1x DDR3L 1066/1333MHz SO-DIMM up to 8GB 1x 2.5" SATA HDD or SSD or SSD module Intel HD Graphics
LCD Touch Panel	LCD Size Brightness Resolution Touch Screen	12.1" (4:3 ratio) 500 nits 1024 x 768 True-Flat PCAP Touch
Expansion	Mini PCI-E Slot	2 (Full & Half-size)
External I/O Ports	USB Serial Port LAN Audio Jack VGA DVI GPIO Power Button	1x USB2.0 Front, 4x USB2.0 Rear 2x RS232, 1x RS232/422/485 (Isolation, terminal block) 2x RJ45 1x Line-out, 1x Mic-in 1x DB15 1x DVI-D 4x DI/ 4x DO (Isolation, terminal block) 1x Front, 1x Rear
Power	Wide Range Power Input Connector	12-48V 3-pole terminal block
Peripheral (Option)	WiFi + BT RFID	802.11 b/g/n WLAN card + BT 4.0 1
Certificate	EMC & Safety	FCC Class B, CE Mark
Environment	Ventilation Dust & Water Proof Operating Temperature Storage Temperature Humidity Operating Vibration Operating Shock	Fanless Front IP66, Rear IP20 0°C ~ 50°C (32°F ~ 122°F) (Still Air) -20°C ~ 60°C (-4°F ~ 140°F) 10% ~ 95% @40°C, non-condensing 5Grms random, 5 ~ 500Hz (1Grms with HDD) (EN 60068-2-6) 20Grms random, 11ms (EN 60068-2-27)
Dimensions (WxDxH)		320 x 88 x 300mm (12.6" x 3.5" x 11.8")
Weight		4.8 kg (10.6 lbs)
Mounting		Panel Mount, VESA Mount 100 x 100
OS Supported		Windows 7 (32/64bit), Windows 8.1 (32/64bit), Windows 10 (32/64bit), Linux

Taiwan - Headquarters

No.168, Sing-ai Rd., Neihu District,
Taipei City 11494, Taiwan, R.O.C.
Tel: 886-2-8791-4988
Fax: 886-2-8791-4966
E-mail: sales@flytech.com.tw
www.flytech.com

U.S.A. - California

271 East Brokaw Road, San Jose,
CA 95112, U.S.A.
Tel: 1-510-257-5180
Fax: 1-510-257-5181
E-mail: sales@flytech.com

China - Shanghai

3F Building 39, No. 333 Qin Jiang Rd.,
Shanghai 200233, P.R.China
Tel: 86-21-5426-1555
Fax: 86-21-5426-1001
E-mail: sales@flytech.com.cn
www.flytech.com.cn

China - Hong Kong SAR

Room 01, 6/F, Block A, Tonic Industrial
Centre, 26 Kai Cheung Road, Kowloon
Bay, Kowloon, Hong Kong
Tel: 852-3525-5800
Fax: 852-2751-7447
E-mail: sales@flytech.com.hk