

K735



Features

- 10.1" True-Flat PCAP Touch
- Intel Bay Trail Processor
- Front IP66, Rear IP20
- Fanless and Silent
- RFID/ WiFi + BT Available
- Front Key-Secured Lock for USB & Power Switch
- Best Panel Mount IPC Solution for Automation Application



IP66



Fanless



WiFi



RFID

As labor costs are increasingly growing, companies in the automation industry are looking to make their factories smarter through improving efficiency, lowering human labor, and continuing to guarantee high product quality. Flytech provides a wide range of industrial touch Panel PC products in different form factors, high brightness displays, and customizable high performance hardware configurations that are designed and certified to work under harsh environments and various automation applications.

K735

Industrial Automation Touch Panel Mount PC

FLYTECH
www.flytech.com

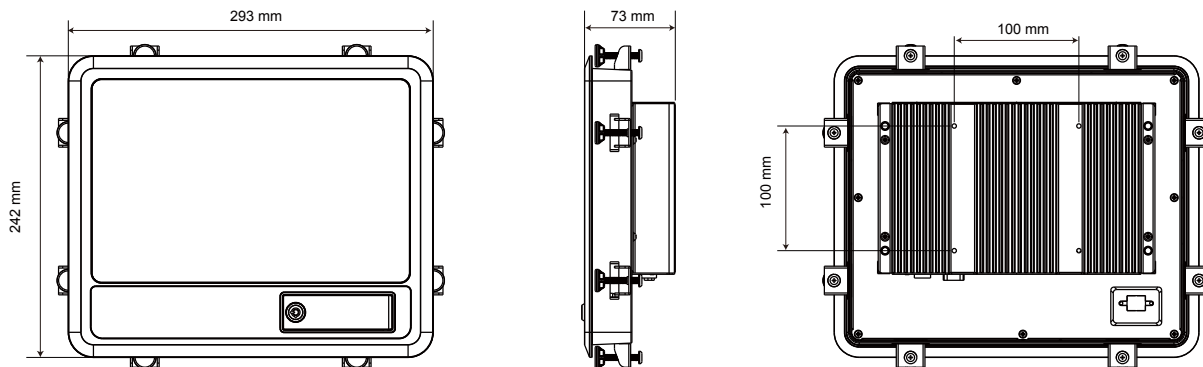

Specification

System	Motherboard	D36
	Processor	Intel Bay Trail CPU Celeron J1900 2.4GHz
	Chipset	CPU Integrated
	System Memory	1x DDR3L 1066/1333MHz SO-DIMM up to 8GB
	Storage Device	1x 2.5" SATA HDD or SSD
	Graphic Engine	Intel HD Graphics
LCD Touch Panel	LCD Size	10.1" (16:9 ratio)
	Brightness	200 nits
	Resolution	1280 x 800
	Touch Screen	True-Flat PCAP Touch
Expansion	Mini PCI-E Slot	1
External I/O Ports	USB	1x USB3.0, 4x USB 2.0
	Serial Port	3x RJ48 (with DB9 convert cable)
	LAN	1x RJ45
	VGA	1x DB15
	Power Button	1x Front, 1x Rear
Audio	Internal Speaker	2x 2W
Power	Power Supply Connector	65W / 19V 4-pole DIN (with latch)
Peripheral (Option)	WiFi + BT	802.11 b/g/n WLAN card + BT 4.0 (either one with 2nd LAN)
	RFID	1 (either one with 2nd LAN)
Certificate	EMC & Safety	FCC Class A, CE Mark, LVD
Environment	Ventilation	Fanless
	Dust & Water Proof	Front IP66, Rear IP20
	Operating Temperature	0°C ~ 35°C (32°F ~ 95°F) (Still Air)
	Storage Temperature	-20°C ~ 60°C (-4°F ~ 140°F)
	Humidity	20% ~ 85% RH non-condensing
	Operating Vibration	5Grms random, 5 ~ 500Hz (1Grms with HDD) (EN 60068-2-6)
	Operating Shock	20Grms random, 11ms (EN 60068-2-27)
Dimensions (WxDxH)		293 x 73 x 242 mm (11.5" x 2.9" x 9.5")
Weight		2.9 kg (6.4 lbs)
Mounting		Panel Mount, VESA Mount 100 x 100
OS Supported		Windows 7 (32/64bit), Windows 8.1 (32/64bit), Windows 10 (32/64bit), Linux

Taiwan - Headquarters

No.168, Sing-ai Rd., Neihu District,
Taipei City 11494, Taiwan, R.O.C.
Tel: 886-2-8791-4988
Fax: 886-2-8791-4966
E-mail: sales@flytech.com.tw
www.flytech.com

U.S.A. - California

271 East Brokaw Road, San Jose,
CA 95112, U.S.A.
Tel: 1-510-257-5180
Fax: 1-510-257-5181
E-mail: sales@flytech.com

China - Shanghai

3F Building 39, No. 333 Qin Jiang Rd.,
Shanghai 200233, P.R.China
Tel: 86-21-5426-1555
Fax: 86-21-5426-1001
E-mail: sales@flytech.com.cn
www.flytech.com.cn

China - Hong Kong SAR

Room 01, 6/F, Block A, Tonic Industrial
Centre, 26 Kai Cheung Road, Kowloon
Bay, Kowloon, Hong Kong
Tel: 852-3525-5800
Fax: 852-2751-7447
E-mail: sales@flytech.com.hk